



SUNCOMBE

CIP, BIOWASTE & PROCESS SOLUTIONS

Dosing Skid



Suncombe Ltd, Jade House, Lockfield Avenue, Brimsdown, Enfield, Middlesex, EN37JY, United Kingdom

T +44(0)20-8443-3454 F +44(0)20-8443-3969 E info@suncombe.com W www.suncombe.com

www.suncombe.com

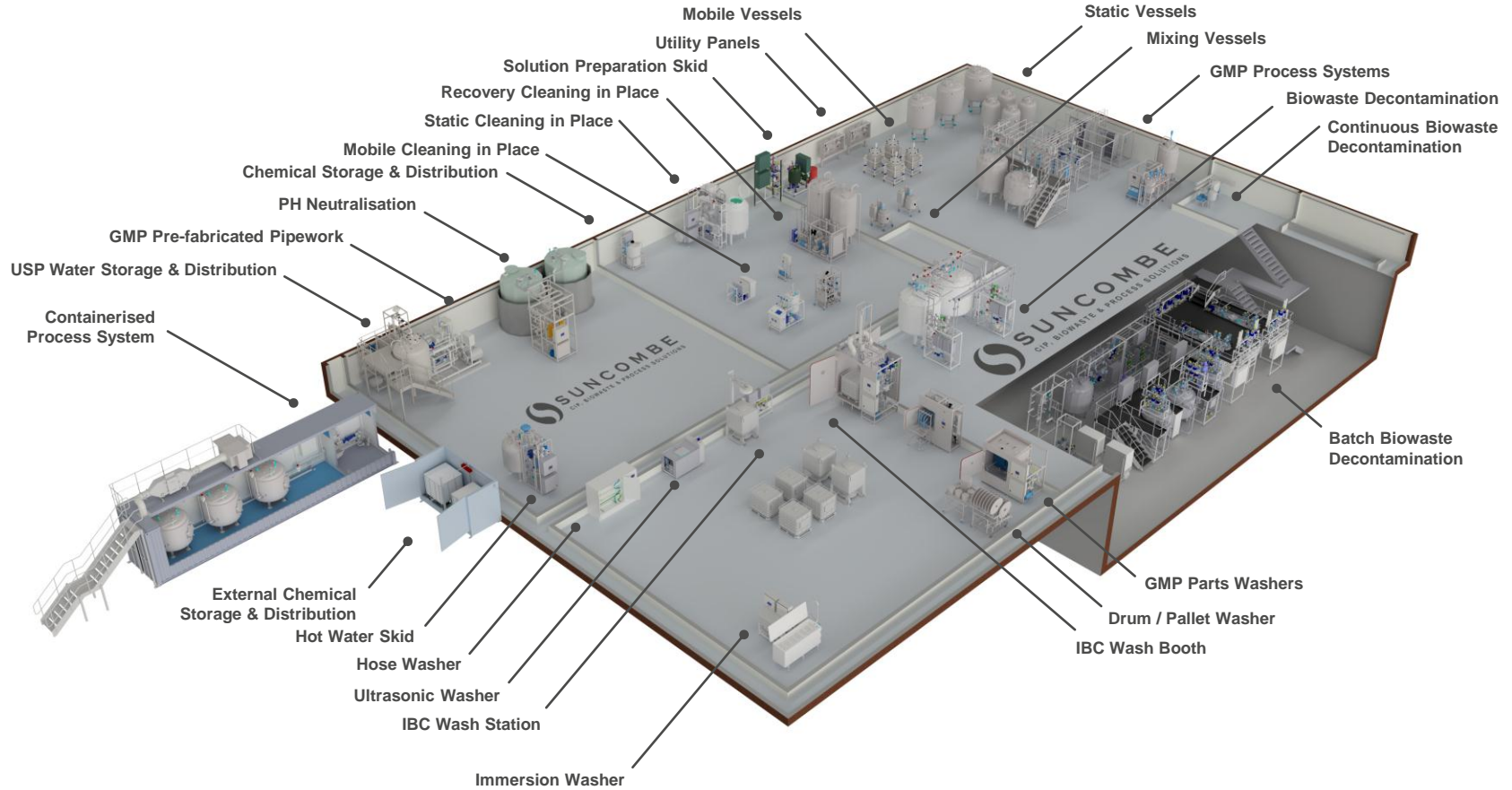

Product Portfolio

Dosing Skids

Suncombe **Dosing Skids** are a robust range of heavy duty validateable skids for liquid dosing applications. Developed for use in the pharmaceutical, biotech, food, beverage, healthcare and other critical sectors, they encompass the high quality of design, manufacture and documentation required in these sectors.

Features

- Developed and manufactured in the United Kingdom
- Designed for accuracy, repeatability and validation
- Available for many liquid solutions and chemical compounds
- Variable Speed High Accuracy Dosing control using stepper motor technology
- High quality stainless, duplex, PE and compatible material Dosing Tanks
- Stainless steel framework and control panels
- 316 stainless steel pipework as standard
- Duplex steel or plastic pipework for chemical compatibility
- Safety Interlocks to SIL2
- High, low and mid level sensing, indication and interlock
- Pressure relief and safety devices
- pH and conductivity control methodologies available
- Risk assessment, method statements, operating instructions and full documentation
- 2D drawings and 3D models supplied
- Factory Acceptance Testing Included

Manufacturing Standards

- 304/316 stainless steel non-wetted parts and framework
- 316 stainless steel product contact parts, 304 non-contact parts, Hastelloy, Duplex Stainless and plastic for chemical compatibility
- T.I.G. Welding; using an argon gas purge, carried out by technicians coded to EN 287, to Suncombe procedures coded to EN ISO 15609, tested to EN ISO 15614 Part 1.
- Electrical and safety design EN 60204

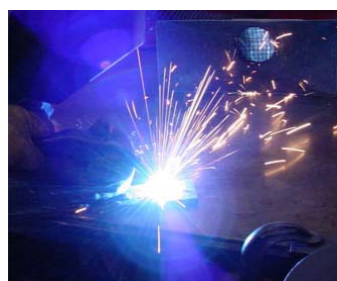

Options

- Standard units available or custom designed to suit your application
- Single, dual or triple pump sets available
- Range of different pump duties available to suit requirement
- Single, dual or triple dosing tanks available
- Stainless steel or plastic guards and covers available
- On board mixing systems together with heating and cooling available
- Mobile or static versions
- For internal or external weatherproof location
- Alternative voltages and build standards for international supply
- Automation integration for multiple systems or for external control systems
- Dataloggers for reporting and records
- Modem link to Suncombe headquarters for on line monitoring
- ATEX or safe area versions



Dosing Skid 300/10

Automation

Offering total flexibility with manual, semi-automatic, automatic and recipe controlled operation, they are designed to be operator friendly and simple to use whilst providing flexibility and optimisation. Reliable and robust, they have been developed over the last 55 years in co-ordination with clients operations staff, engineers and validation staff. They encompass all elements required to provide an accurate, safe, controllable, repeatable system.



Level 1000 Basic System

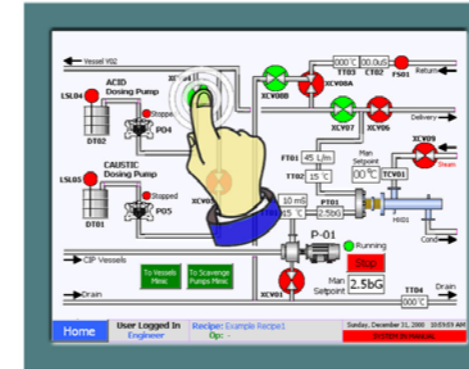

Level 3000 Advanced System



Dosing Skid 200/5



Triple Dosing Skid 50/1

Equipment Dimensions

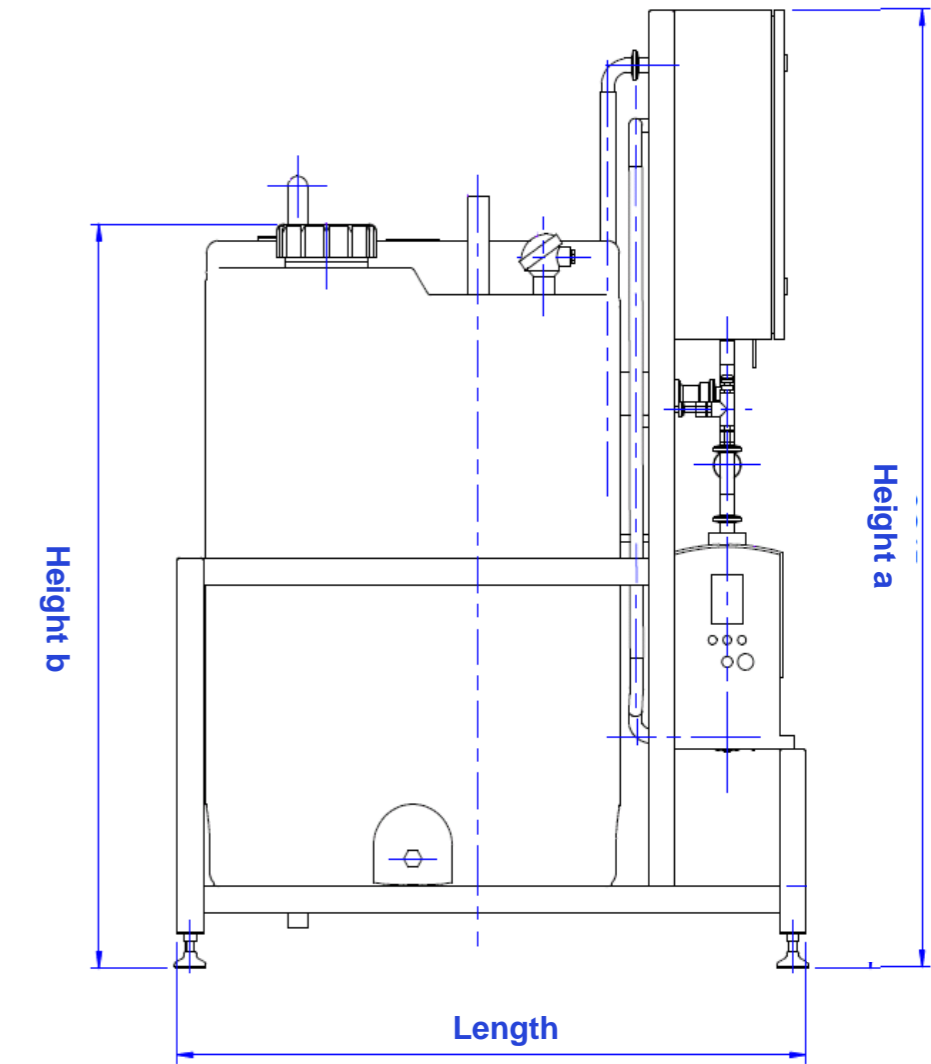

Elevation View

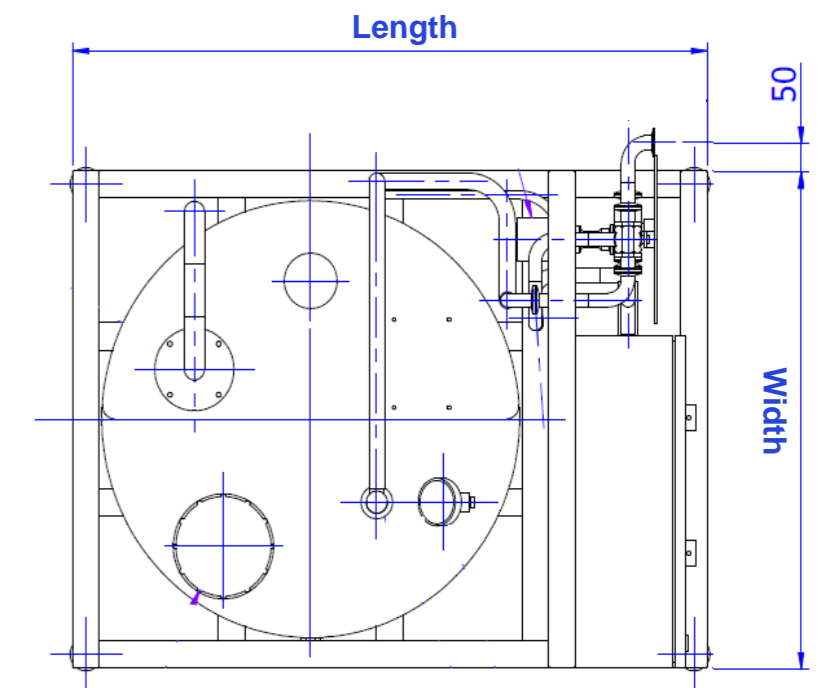

Plan View

Part #	Duty Details			External Dimensions mm			
	Storage Volume (litres)	Outlet Flowrate (litres per minute)	Outlet Pressure (barg)	Width	Length	Height a	Height b
Dosing Skid 50/1	50	0-1	4	700	1100	1750	650
Dosing Skid 100/3	100	0-3	6	700	1100	1750	850
Dosing Skid 200/5	200	0-5	4	900	1300	1750	950
Dosing Skid 300/10	300	0-5	6	900	1300	1750	1250
Dosing Skid 500/15	500	0-15	6	1000	1400	1850	1250
Dosing Skid 1000/15	1000	0-15	6	1250	1650	1850	1500

